

NSPS

**SURVEY TECHNICIAN CERTIFICATION
PROGRAM**

**LEVEL 1
SAMPLE EXAMINATION**



NATIONAL SOCIETY OF PROFESSIONAL SURVEYORS

January 2024

This booklet has been prepared to provide an example of what an actual Certified Survey Technician (CST) Examination might be like. Using this as your only study guide is not recommended.

This examination is approximately 25% of an exam. The work element order is the same as in the full examination with approximately one half the number of questions

These are not exactly questions from past exams, but do reflect the complexity and makeup of actual exam questions.

Additional information about the CST program and exam availability can be obtained at:

- www.cstnsps.com
- (240) 439-4615
- NSPS CST Program
21 Byte Court, Suite H
Frederick, MD 21702

A complete list of recommended books can be found on the CST website under the Applicants section. The recommended books mentioned are not particularly endorsed for any specific reason nor are they endorsed by the NSPS or other Survey related Association or Society. They represent a cross section of how, where, and what may be utilized as a resource to derive methods of study in preparation for the CST Exams.

At minimum an examinee should bring:

- 1). A Fundamental Surveying Text (with Unit Conversion Charts)
- 2). A First Aid & Safety Manual
- 3). Definitions of Surveying and Associated Terms (NSPS)

LEVEL 1
SURVEY TECHNICIAN CERTIFICATION
POSITION DESCRIPTION, WORK ELEMENTS AND NUMBER OF QUESTIONS

This is an open book exam.

POSITION DESCRIPTION

Level I Technicians are required to demonstrate knowledge of basic first aid skills and safety requirements. The individual in this position possesses a basic knowledge of field operations and types of surveys as well as familiarity with field equipment and procedures used in these functions. Additional skills required include computational ability, survey note taking, drafting/CAD and map reading. Work Elements further describe the requirements related to this position.

WORK ELEMENTS

Test problems will be taken from the following work elements: (# questions from each Work Element)

- 1) *Survey Types and History* (15)
Knowledge of the different types of surveying and the basic differences between them.
Knowledge of the historical development of survey procedures and practices

- 2) *Field Equipment & Operations* (75)
Knowledge of the care, cleaning and use of surveying tools and equipment, including field radios.
Understand the names, purpose and parts, setup, transport and the need for calibration of various surveying field instruments. Some historical knowledge of equipment and operations is required. Knowledge of the field duties of a Survey Technician such duty areas may include line clearing, establishing points, taping, leveling and compass reading. Knowledge of the basic types of surveying field notes.

- 3) *Survey Control* (6)
Knowledge of types of survey control points and their differences

- 4) *Survey Computations* (50)
Knowledge of mathematics and measurements relating to surveying (including linear, angular, slope calculations, elevations and unit systems conversion).

- 5) *Office Operations, Plan Reading and Preparation* (34)
Knowledge of the types of surveying maps and the ability to obtain basic information from these maps.
Knowledge of basic drafting and CAD skills and procedures.

- 6) *First Aid & Safety* (20)
Basic knowledge of treatment practices for a variety of medical emergencies. Knowledge of traffic control and safety procedures for surveying and construction operations, including Occupational Safety and Health Administration (OSHA) standards.

TOTAL NUMBER OF QUESTIONS = 200, TIME = 4 hours

CST Level I Sample Test and Answers & Guide

January 2023

Survey Types and History (3)

1. Which of the following is NOT a historical unit of measurement?
 1. Vara
 2. Gunter's chain
 3. Bannekar
 4. Engineer's Chain
2. In a mining Survey, you are asked to survey a new adit. what is an adit?
 1. a tunnel driven for mine drainage, ventilation, or transportation
 2. a main haulage road underground
 3. an excavation made at the bottom of a shaft
 4. the angle at which a bed or stratum is inclined from horizontal
3. Hydrographic surveys must be referenced to which of the following datum/s?
 1. Horizontal only
 2. Horizontal and Vertical
 3. Vertical only
 4. Tidal

Field Equipment & Operations (18)

4. To assure proper plumb of a prism pole you would use a(n):
 1. Hand Level
 2. Bull's eye level
 3. Spirit or Tube Level
 4. Plumb Bob
5. A call for "high" rod from the instrument operator means the telescoping level rod is:
 1. backwards
 2. not being held Level
 3. upside down
 4. collapsed

6. As you go uphill from the instrument with a level rod held vertical, the readings observed by the level operator are:
 1. Getting smaller
 2. Getting harder to see
 3. Getting easier to see
 4. Getting larger

7. Stadia cross hairs are used:
 1. For three-wire leveling
 2. When adjusting the instrument
 3. for determining instrument error
 4. when adjusting instrument

8. How many leveling screws are on a tribrach?
 1. one
 2. two
 3. three
 4. four

9. A reflectorless total station is most useful for:
 1. Inaccessible points
 2. angles and distances needed rapidly
 3. only angles are needed
 4. only distances are needed

10. A ground-based laser scanner measurement produces
 1. a photographic image
 2. a horizontal coordinate file
 3. a point cloud
 4. a vertical coordinate file

11. The reason for totally discharging most nicad batteries before recharging is:
 1. variability of electrical current
 2. development of a "memory"
 3. development of a change in voltage
 4. leaking

12. What would be the quickest instrument to use to obtain a ground elevation of a point just down slope from a bench mark?
1. hand level
 2. Total station
 3. Self-leveling level
 4. Dumpy level
13. Why is it important to balance back-sight and fore-sight distances when conducting a differential level circuit?
1. It simplifies your computations and prevents blunders.
 2. Ease in finding turning points
 3. Ease of reading the level rod graduations.
 4. Helps eliminate errors caused by an instrument that is out of adjustment.
14. Why would you stack more than one prism on a setup?
1. provide a greater distance between upper and lower stadia readings
 2. give the observer a better line of sight
 3. Provide more reflective area
 4. improve the phase signal
15. Most total station measure distances based upon:
1. light waves
 2. Stadia measurements
 3. Distance between upper and lower transit readings
 4. sound waves
16. A cross section must extend:
1. along profile of centerline
 2. at PC only
 3. at PT only
 4. right and left of centerline
17. A slope stake:
1. gives grade and elevation
 2. gives location where cut or fill ends
 3. lists the invert elevation
 4. lists the PC station

18. Which of the following procedures would result in the largest error in a 100-foot standardized steel tape?
1. Steel tape is 2 feet off line
 2. Steel tape on a 5% slope without correcting
 3. Tape is supported throughout with too much tension
 4. Suspended tape is supported at both ends with 10 lbs. of tension.
19. Cross-section areas are used to calculate:
1. The length of stations on a curve
 2. Right angle offsets from the centerline
 3. The excavation fill total
 4. Total excavation quantities
20. The purpose of rocking a level rod on a point during a level circuit is:
1. to allow the instrument operator to observe the highest rod reading
 2. to reduce error due to refraction
 3. so the instrument operator can determine if the rod is on the highest point of the monument
 4. to allow the instrument operator to determine when the rod is vertical over the monument
21. Survey notes are usually recorded:
1. During lunch break
 2. At the time of the field work
 3. Back in the office at the end of the day
 4. Before the work is done

Survey Control (3)

22. Which of the following would be the best "TBM"?
1. middle of the sidewalk
 2. top of a fire hydrant
 3. edge of asphalt
 4. top of anchor bolt

23. The National Spatial Reference System (NSRS) control points are classified in a ranking scheme based on the
1. order of accuracy
 2. geographic location
 3. the agency that created them
 4. the date when they were established
24. What is the primary federal agency responsible for the network of reference control monuments in the United States?
1. BLM
 2. NGA
 3. NGS
 4. USGS

Office Operations, Plan Reading and Preparation (10)

25. A rectangular borrow area was measured on a map with scale 1 inch = 100 feet. How many acres does the area contain if the area measured 5.7 inches x 8.6 inches.
1. 1.1
 2. 11.3
 3. 15.3
 4. 16.2
26. A topographic map indicates a slope ratio of 3:1. If the horizontal distance scales 27 feet, what is the vertical distance?
1. 1
 2. 9
 3. 30
 4. 81
27. The scaled distance between two points on a 7-1/2 minute USGS Quadrangle map is 7-1/2 inches. What is the ground distance in feet between the two points? (Map scale is 1:24,000)
1. 45,000
 2. 90,000
 3. 15,000
 4. 18,000

28. What are the coordinates of the southwest corner of the northwest building? (Fig1284)

1. N 10,600, E 10,800
2. N 10,640, E 10,560
3. N 10,800, E 10,600
4. N 10,800, E 10,800

FIGURE 1284

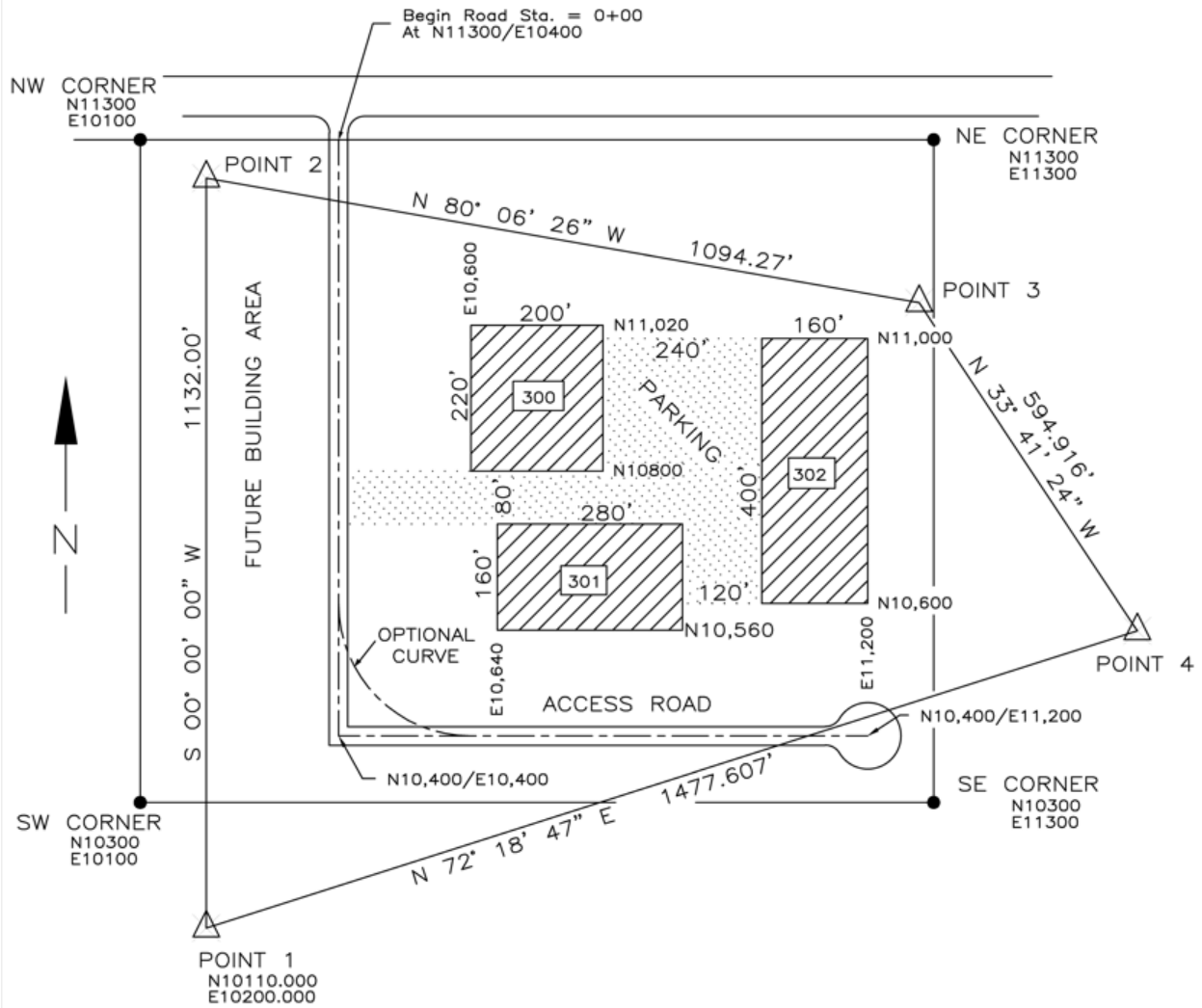

29. An as-built survey (Scale 1"=50') shows a building 96'8" long. How many inches long would this line be drawn?
1. 1.68
 2. 1.93
 3. 1.94
 4. 8.07
30. What is the bearing from traverse Point 4 to Point 1 in Figure 1284?
1. N 33° 41' 24" W
 2. N 72° 18' 47" W
 3. S 72° 18' 47" W
 4. N 80° 06' 26" W
31. Which of the following is NOT an element of a horizontal curve?
1. Long chord
 2. Length
 3. Radius
 4. Slope
32. You have plotted a road profile. The curve you are looking at is a _____ curve.
1. Horizontal
 2. Reverse
 3. Spiral
 4. Vertical
33. The manual tool used to draw a small circular curve is a :
1. Compass
 2. French Curve
 3. Proportional divider
 4. Protractor
34. A rule for placing text in CAD is that all text should be placed so that it can be read from the _____ side.
1. Center
 2. Bottom
 3. Bottom and right
 4. Bottom and left

Survey Computations (12)

The following problems require basic math, geometry, trigonometry, comprehension of Survey drawings, maps, worksheets and how to interpret this data into something useful per each dilemma. Again, there isn't any one definitive book or media to rely on for a straight forward answer to these problems. It is through experience and familiarity of how they interact that there comes a wisdom of what is needed to be done. Studying a Math course geared toward Survey & Engineering is a solid beginning into the Computation World of Surveying.

35. Convert 60° Centigrade (Celsius) to degrees Fahrenheit.
1. 92
 2. 115
 3. 140
 4. 165
36. What is the area, in acres, of a rectangular tract of land with dimensions of 360 feet x 242 feet?
1. 1.8
 2. 2.0
 3. 2.4
 4. 3.6
37. After an increase of 6%, the annual budget for software for a survey company was \$15,434. Find the previous budget value.
1. \$13,779
 2. \$14,000
 3. \$14,560
 4. \$15,000
38. The area of a circle with a radius of 15 feet is _____ square feet
1. 706.86
 2. 176.71
 3. 225.01
 4. 900
39. A circle with a diameter of 1000 ft is divided into quarters. What is the area of each portion in acres?
1. 3.8 acres
 2. 4.5 acres
 3. 5.7 acres
 4. 18 acres

40. What is the sum of: $85^{\circ} 43' 21''$, $14^{\circ} 30' 00''$, $67^{\circ} 56' 49''$
1. $166^{\circ}09'10''$
 2. $167^{\circ}19'10''$
 3. $167^{\circ}30'10''$
 4. $168^{\circ}10'10''$
41. In a survey that requires a precision of 1:10000, a line 500 feet long would have to be measured to the nearest:
1. hundredth of a foot
 2. five hundredths
 3. tenth of a foot
 4. foot
42. An earthwork quantity increased from 20,633 cu yds to 21,252 cu yds. What is the percent of increase? Correct to the nearest tenth of one percent.
1. 1
 2. 1.1
 3. 3
 4. 5.4
43. You are given the information that the total area of a proposed excavation site is 97,530 square meters. You need to provide the information in acres. How many acres is this?
1. 1024.3
 2. 24.1
 3. 241.0
 4. 312.3
44. A slope distance of 495.31 is measured at a zenith angle of $97^{\circ}25'$. What is the horizontal distance?
1. 488.06
 2. 491.17
 3. 491.35
 4. 502.56
45. If the side slope is 1 1/2 to 1, what is the area of fill from the right top of slope to the toe? (Figure 82)
1. 29.2 ft²
 2. 97.5 ft²
 3. 194.9 ft²
 4. 292.4 ft²

FIGURE 0082

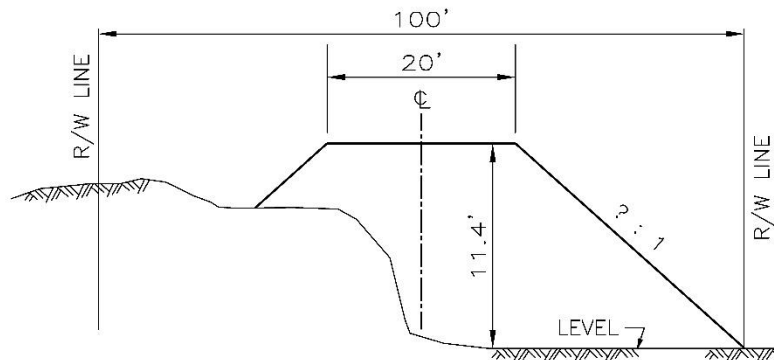

46. If you read 5.00 on a benchmark with an elevation of 980.41 and then read 8.56 on a turning point, what is the elevation of the turning point?
1. 971.85
 2. 976.85
 3. 983.97
 4. 993.97

First Aid & Safety (5)

The following problems require understanding First Aid, CPR, OSHA Regulations and comprehending the value of abiding and enforcing Safety by practicing good work habits. Red Cross pamphlets, books, and OSHA Regulations are available online or can be purchased for review and study. A course in First Aid and/or CPR is also an excellent way to learn the importance of safety and receive training at the same time. Again, these problems do not have a single definitive book to derive answers from. Experience, training (First Aid, CPR, etc....) and studying the guidelines of safe work habits are an accumulative effort.

47. Safety is the responsibility of:
1. Each individual
 2. The property owner
 3. The equipment supplier
 4. The owner of the company

48. The letters OSHA stand for:

1. Organization of Street and Highway Agencies
2. Occupational Safety and Health Administration
3. Organization for Safety in Housing Agency
4. Office of Safety and Health Administration

49. Which of the following is a safe practice around traffic?

1. Use traffic cones to protect only field equipment.
2. should wear ear plugs and earmuffs
3. should use signs to warn motorists of survey activities on the roadway
4. park a vehicle to block traffic

50. While surveying in a metropolitan area a tornado warning is issued, persons in the path of the storm should immediately:

1. find shelter in a building and shut all windows tightly
2. sit in a parked automobile
3. stand behind a large tree
4. take cover in an interior area on the lowest floor of building

51. Why is it not recommended that survey party members wear soft-soled shoes?

1. Other survey party members may not like the color of tennis shoes
2. They're easily penetrated by sharp stubs, nails or glass
3. Snakes like tennis shoes
4. Tennis shoes get wet

CST Level 1 Sample Test Answers & Guide

January 2023

NOTE: In many instances the answer will reference “Elementary Surveying” 14th edition by Ghilani and Wolf (2015). For example: G&W 14th p 545. However, other introductory surveying textbooks should also provide information.

The “Definitions of Surveying and Associated Terms” (2005, American Congress on Surveying and Mapping in collaboration with the University of Maine) abbreviated as **DSAT**, will also be helpful in answering many of the questions.

1. #3 Bannekar see G&W 14th p 23
2. #1 a tunnel driven for mine drainage, ventilation, or transportation see DSAT p10
3. #2 horizontal and vertical see G&W 14th p 489
4. #2 Bull’s eye level see G&W 14th p 85
5. #4 collapsed see G&W 14th p 90
6. #1 Getting smaller see G&W 14th p 103, fig 5.4
7. #1 For three wire leveling see G&W 14th p 112, 119 and 556
8. #3 three see G&W 14th p 189, fig 8.3
9. #1 Inaccessible points see G&W 14th p 150, 680
10. #3 a point cloud see G&W 14th p 479
11. #2 development of a memory see <http://thescienceexplorer.com/technology/should-you-let-your-rechargeable-batteries-drain-completely-recharging-them>
12. #1 hand level see G&W 14th p 88
13. #4 Helps eliminate errors caused by an instrument that is out of adjustment.

 see G&W 14th p 106
14. # 3 provide more reflective area for obtaining the measurement see G&W 14th p148
15. #1 light waves see G&W 14th p 142
16. #4 right and left of centerline see G&W 14th p 768

- 17. #2 gives location where cut or fill ends see [G&W 14th p 691](#)
- 18. #2 Steel tape on a 5% slope without correcting see [G&W 14th p 135-141 and table 6.1](#)

This is a problem evaluation different errors in taping

a 100' steel tape 2 ft. off line will create an error of $Csl = -d^2/(2L) = 2^2/(2 \times 100) = -0.02'$

a 100' steel tape on a 5% slope will create an error of $Csl = 5^2/200 = 0.125'$

a 100' steel tape being pulled with 15# of excess pull will create an error of 0.01'

a 100' steel tape suspended with only 10 # (a shortage of 15%) pull will create an error of 0.01'

So, the **5% slope distance** not being a horizontal distance would cause the largest error

- 19. #4 Total excavation quantities see [G&W 14th p 768](#)
- 20. #4 to allow the instrument operator to determine when the rod is vertical over the monument..... see [G&W 14th p 100-101](#)
- 21. #2 At the time of the field work see [G&W 14th p 28](#)
- 22. #4 top of anchor bolt see [G&W 14th p 17](#)
- 23. #1 order of accuracy see [G&W 14th p 545](#)
- 24. #3 NGS see [G&W 14th p 14](#)

- 25. #2 11.3 acres

This is essentially a units conversion problem.

For a scale of 1" = 100' a square inch would be 100x100 square feet or 10,000 ft²/in²

So for a 5.7" by 8.6" area or 49.02 in² on the map, the ground area would be

$49.02 \text{ in}^2 \times 10,000 \text{ ft}^2/\text{in}^2 = 490,200 \text{ ft}^2$

Since there are 43,560 ft²/acre, this would be $490,200 \text{ ft}^2/43,560 \text{ ft}^2/\text{acre} = \mathbf{11.253 \text{ acres}}$

- 26. #2 9 feet

A slope ratio of 3:1 means a 1 ft rise in 3 ft of run (horizontal)

In 27 horizontal feet there are 9 different 3 ft sections.

Since there is a 1 ft drop for every 3 ft of run, the vertical distance would be 9 ft

- 27. 15,000 feet

A map scale of 1:24,000 is a representative fraction scale

or 1" on the map = 24,000 inches on the ground

To convert it to an equality scale of 1" = something feet we would have to

Convert the 24,000 inches on the ground to feet on the ground

24,000 inches/(12 inches/1 ft) = 2000 ft So the equality scale would be 1" = 2000'

On this map then, 7 1/2 inches would be 7.5" x 2000'/" = 15,000 feet on the ground

28. #3 N 10800, E 10,600

From inspection of the plan, the easting of the corner is **E 10,600** and the northing is **N 10,800**

FIGURE 1284

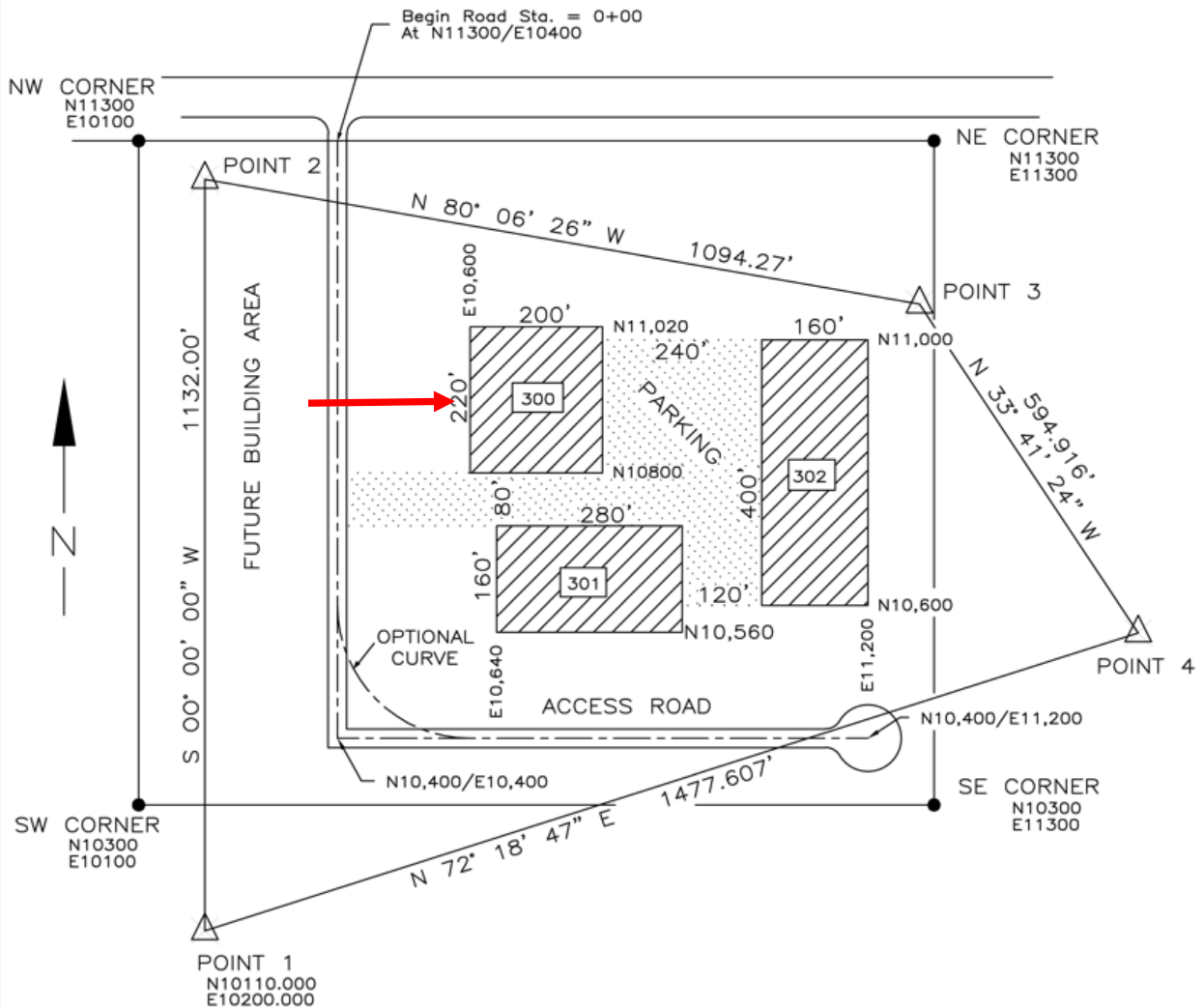

29. #2

For a scale of 1" = 50' a building 96.8" or 96.666 ft would be $96.666 \text{ ft} / (50 \text{ ft}/1\text{inch}) = \underline{1.933''}$

30. #3 S 72°18' 47" W

31. #4 Slope

32 #4 Vertical

33. #1 Compass

34. #3 Bottom and right

35. #3 140 degree Fahrenheit

General equation is: $^{\circ}\text{F} = (^{\circ}\text{C} \times 9/5) + 32$ or $^{\circ}\text{C} = (^{\circ}\text{F} - 32) \times 5/9$ so for this question,

$^{\circ}\text{F} = (60^{\circ}\text{C} \times 9/5) + 32 = (60 \times 1.8) + 32 = \underline{140^{\circ} \text{ Fahrenheit}}$

36. #3 2.0 acres

$360 \text{ ft.} \times 242 \text{ ft.} = 87,120 \text{ ft}^2$

$(87,120 \text{ ft}^2) / 43,560 \text{ ft}^2 \text{ per acre} = \underline{2.0 \text{ acres}}$

37. #3 \$14,560

Old Budget + (Old Budget) 6% = \$15,434

or $1.06 \text{ Old Budget} = \$15,434$

so Old Budget = $\$15,435 / 1.06 = \$14,560.68$ or \$14,560

38. #1 706.86

Area of a circle = $\pi R^2 = 3.14159 \times (15')^2 = 3.14159 \times 225 = \underline{706.86 \text{ ft}^2}$

39. #2 4.5 acres

Area of circle = $\pi R^2 = 3.14159 \times (500 \text{ ft})^2 = 785,398 \text{ ft}^2$

One quarter of $785,398 \text{ ft}^2 = 785,398 / 4 = 196,340 \text{ ft}^2$

$196,340 \text{ ft}^2 / 43,560 \text{ ft}^2 \text{ per acre} = 4.507 \text{ acres}$ or 4.5 acres

40. #4 168°10'10"

Be certain to decimalize each angle before adding them together.

Then remember to put them back into DMSD format for answer

41. # 2 five hundredths

1:10,000 precision can be thought of as 1 ft. error in 10,000 ft.

So 1ft. /10,000 ft. = ? ft./500 ft.

Or 500 ft. / 10,000 ft. = ? ft. = 0.05 ft. or five hundredths

42. # 3 3% increase

Increase in earthwork quantity = 21,252 cy – 20,633 cy = 619 cubic yards

So 619 CY = ?% of 20,633 cy

?% = 619 cy / 20,633 = 0.300 = 3%

43. #2 24.10 acres

(the site does not actually have to be a square but this approach is one way to tackle the problem)

If the site encompasses 97,530 m² then taking the square root would tell us it must be 312.30 m by 312.3 m.

If 1 ft (international) = 0.3048 m (see **G&W 14th inside front cover**) then the site is

312.30 m x (1 ft./0.3048 m) = 1024.6 ft. by 1024.6 ft.

1024.6 ft x 1024.6 ft. = 1,049,804 ft²

And since 1 acre is 43,560 ft² then 1,049,804/43,560 = 24.1 acres

Another approach if you knew that 1 ft. = 3.2808398 m then 1 ft.² = 10.7639 m²

So 97,530 m² / 10.7639 ft.²/m² = 1,049,804 ft.² or 24.1 acres

44. # 2 491.17 ft.

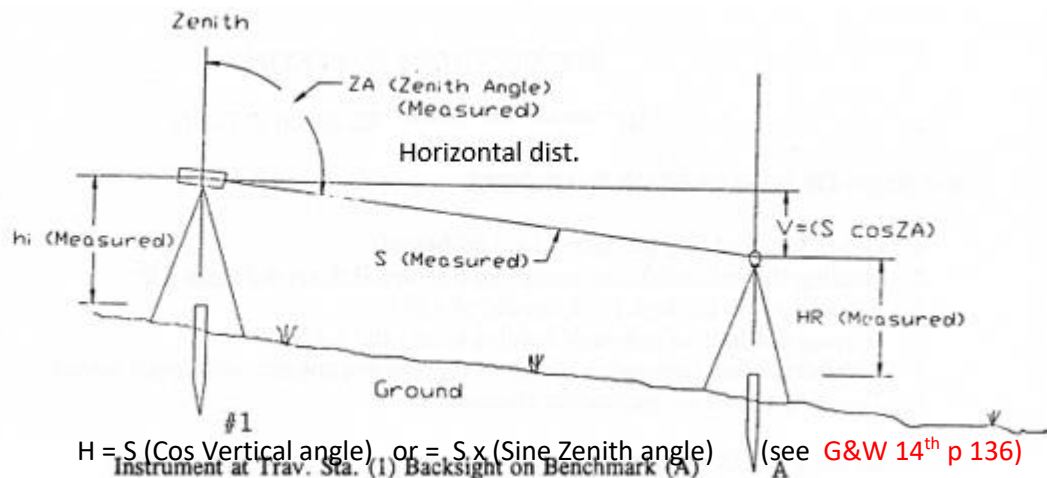

In this case $H = 495.31 \text{ ft.} (\text{Sine } 97^\circ 25') = 495.31 (.991633655) = 491.166$ or 491.17

(Remember to decimalize the angle before obtaining the sine function)

45. #2 97.5 ft²

FIGURE 0082

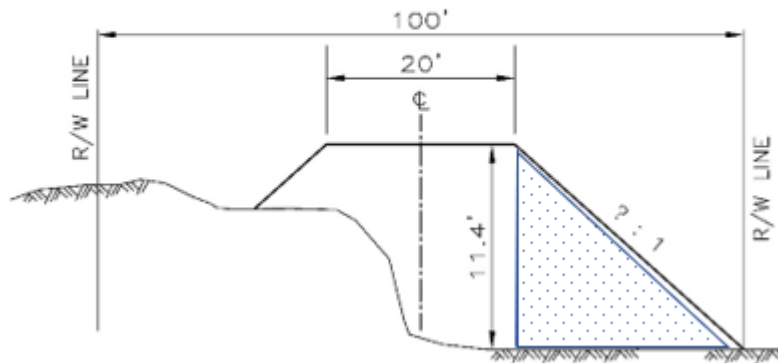

For a 1.5 to 1 slope a rise of 11.4 ft. would require a “run” or horizontal distance of

$$1.5 \times 11.4 = 17.1 \text{ ft.}$$

Then for a right triangle with a base of 17.1 ft. and a height of 11.4 ft. would be

$$\frac{1}{2} b \times h \text{ or } 0.5 \times 17.1 \times 11.4 = 97.47 \text{ or } \underline{97.5 \text{ ft}^2}$$

46. #2 976.85

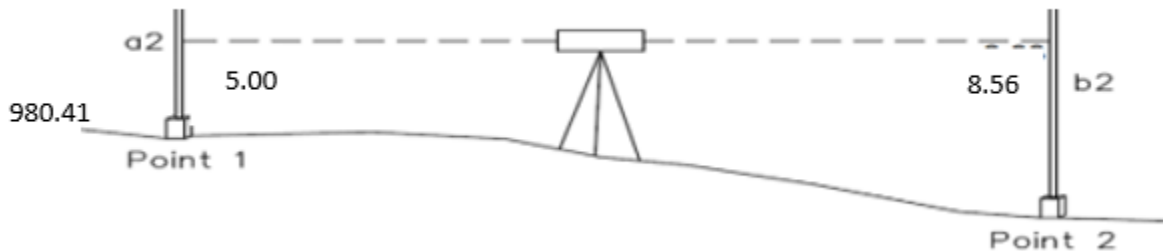

Elevation + Back sight = HI so $980.41 + 5.00 = 985.41$

HI – fore sight = turning pint elevation so $985.41 - 8.56 = \underline{976.85}$

47. # 1 Each individual

48. # 2 Occupational Safety and Health Administration

49. # 3 should use signs to warn motorists of survey activities on the roadway

The most practical and effective of the answers

50. # 4 take cover in an interior area on the lowest floor of building

<https://www.redcross.org/about-us/news-and-events/news/2019/tornadoes-how-to-stay-safe.html>

51. # 2 They're easily penetrated by sharp stubs, nails or glass

The most logical answer